VPFlowScope In-line 3/8"

User manual

© 2021 VPIstruments

VPFlowScope In-line 3/8"

© 2021 VPInstruments

All rights reserved. No parts of this document may be reproduced in any form or by any means - graphic, electronic, or mechanical, including photocopying, recording, taping, or information storage and retrieval systems - without the written permission of the publisher.

Products that are referred to in this document may be either trademarks and/or registered trademarks of the respective owners. The publisher and the author make no claim to these trademarks.

While every precaution has been taken in the preparation of this document, the publisher and the author assume no responsibility for errors or omissions, or for damages resulting from the use of information contained in this document or from the use of programs and source code that may accompany it. In no event shall the publisher and the author be liable for any loss of profit or any other commercial damage caused or alleged to have been caused directly or indirectly by this document.

Creation date: 25-01-2021 in Delft

Publisher

Van Putten Instruments BV
Buitenwatersloot 335
2614 GS Delft
The Netherlands

Table of Contents

1 Warning - Read this first	4
2 Introduction	5
3 Product overview	6
4 Quick start	6
5 Measurement	7
1 Flow	7
2 Totalizer	7
6 Mechanical installation	8
1 Installation point	8
2 Piping table	8
7 Connectivity & communication	10
1 LEDS	10
2 4 .. 20 mA output	10
3 Pulse	11
4 RS485	12
5 Display	12
Keypad	12
8 Modbus	13
9 Electrical connections	16
1 4 .. 20 mA	16
2 RS485	17
10 Specifications	19

1 Warning - Read this first

	<p>Compressed gases can be dangerous! Please familiarize yourself with the forces under pressurized conditions. Respect the local guidelines and regulations for working with pressurized equipment.</p>
	<p>Gas flow through pipes follows certain physical laws. These physical laws have serious consequences for the installation requirements. Familiarize yourself with the basic physical laws of flow measurement, to make sure that the product is installed correctly. Always make sure that upstream length, downstream length, flow, pressure, temperature and humidity conditions are within specifications.</p>
	<p>Precision instruments need maintenance. Check your flow meter regularly and make sure it remains clean. When polluted, gently clean the sensor using de-mineralised water or cleaning alcohol.</p>
	<p>Not intended for fiscal metering or billing. Our flow meters are not certified for fiscal metering. Laws on fiscal metering and billing may vary per country or state.</p>
	<p>Do not overestimate the results. VPI instruments does not take any responsibility for the correctness of measurement results under field conditions. The practical measurement uncertainty of a flow meter in the field may vary, depending on how well it is installed, due to the nature of gas flow. The piping table provides guidelines on how to optimize the field accuracy. Our products are not intended to be used as a single means to determine compressor capacity.</p>
	<p>Do not open the device. Our instruments are assembled with high precision. Opening this device is dangerous and may destroy the instrument. Warranty is voided when you open the instrument.</p>
	<p>Feedback leads to product improvement. Please share your experience with us, as we are continuously improving our products in our commitment to quality, reliability and ease of use. Let us know via sales@vpinstruments.com!</p>

2 Introduction

Thank you for purchasing the VPFlowScope In-line 3/8" flow meter. This flow meter is designed to measure low flow rates of air and oxygen. The built in display will show the actual and total flow and the Modbus and analog 4..20 mA output enable you to interface with 3rd party monitoring systems.

We have done our best to make this user manual as complete as possible. New users, please read it carefully to familiarize yourself with our products. Experienced users can check out the [Quick start chapter](#).

Check the packaging box for any inconsistencies. Should there be any shipping damage, notify the local carrier. At the same time a report should be submitted to Van Putten Instruments BV, Buitenwatersloot 335, 2614 GS DELFT, The Netherlands.

This manual is dedicated to:

VPFlowScope In-line 3/8" flow meter

3 Product overview

The VPFlowScope In-line 3/8" is a flow meter which measures flow rates of air and oxygen in 3-8 inch pipes. The actual flow rate and the total flow will be shown on the display in selectable units. The Modbus and analog 4..20 mA output enables you to interface with 3rd party monitoring systems.

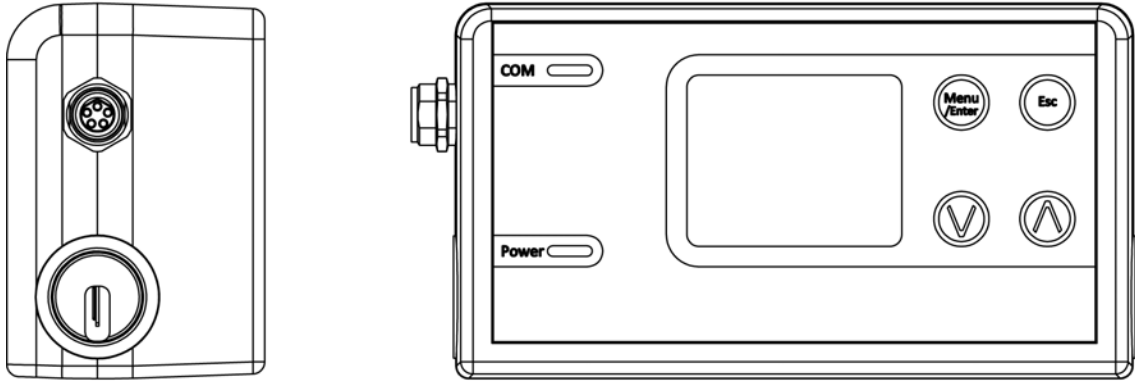

4 Quick start

This chapter contains the basic steps to start using your VPFlowScope In-line 3/8" flow meter. Additional information on all subjects can be found in the next chapters.

1. Unpack

Unpack the box and check if all items are there and in good shape.

2. Apply power

Connect the unit to a DC power source (14 .. 24 VDC). [See chapter 9 Electrical connections](#) for more information.

3. Mechanical installation

- Find the best point of installation for this product. Make sure that the process conditions are within the specifications of the flow meter and the upstream and downstream straight pipe lengths are respected.
- For installation of the flow meter, the pipe needs to be cut.
- Mount the flow meter between the pipe ends using Hylok SICMC-6-6G.
[See chapter 6 Mechanical installation](#) for more detailed information.

4. Electrical installation

Connect a cable with 5 Pin M8 connector to the flow meter. The cable can be connected to a central data acquisition / building management system or data logger via Modbus RTU or 4..20 mA. Apply 14 .. 24 VDC to power up the device. Use a Class II power supply (less than 2 Amps). [See chapter 9 Electrical connections](#) for more information.

5. Configuration

No configuration is required for proper measurement. Configure the Modbus address or the 4..20 mA settings when they are used. These settings can be changed in the menu using the buttons.

Optionally the displayed units can be changed. By default they are set to:

- Row 1: flow in l/m
- Row 2: total flow in l
- Row 3: temperature in °C

It is possible to switch between 1, 2 or 3 parameters.

5 Measurement

For all parameters the update interval is 1 second. Within this second, multiple samples are taken and averaged to provide a stable and reliable output.

5.1 Flow

The VPFlowScope In-line 3/8" flow meter uses our proprietary insertion type thermal mass flow sensor. There is no bypass flow, which results in a high robustness and less sensitivity for dirt or particles. The flow sensor is directly temperature compensated. The flow reading is under normalized conditions.

The sensor response signal is directly related to the mass flow rate and can be described by the following formula:

$$V_{out} = k * \gamma * v * (T_s - T_g)$$

V_{out} = output voltage

k = sensor (geometrical) constant

γ = thermal conductivity of the gas

v = density of the gas

v = actual velocity in m / sec

T_s = sensor temperature

T_g = gas temperature

5.2 Totalizer

The totalizer keeps track of the total consumed amount of compressed air in normal cubic meters, normal liters, normal centiliters or in (M)(M)SCF depending on which unit you choose to read out. The refresh interval is 1 second. Actual totalizer data will be available on the display and via the Modbus interface. The totalizer value is written to its internal memory with an interval of 15 minutes. A power failure may result in maximum 15 minutes of totalizer data loss.

The totalizer can only be reset to zero. It's not possible to set it to any arbitrary value.

6 Mechanical installation

6.1 Installation point

The installation point is crucial for a correct measurement. Sources of error can be: installation effects, unknown flow profiles, swirls, pressure and temperature effects, humidity effects, oscillations in the flow, etc. To ensure the highest possible accuracy of flow measurement, the installation and piping instructions must be followed. Therefore read this paragraph carefully.

Take into account:

- Choose a location which is accessible, which allows access for wiring and maintenance activities.
- Meet the specifications of the VPFlowScope In-line 3/8" flow meter. When the specifications are not met, for instance the pressure or temperature level is too high; this will cause inaccurate flow measurement and can even damage your flow meter.
- Do not apply mechanical stress on the VPFlowScope In-line 3/8" flow meter.

Avoid:

- Excessive heat, check the temperature specifications
- Corrosive atmosphere where possible
- Electrical problems (high voltage/ high power)
- Mechanical vibration and danger (walking bridges, fork lift trucks)
- Any environmental source of potential error



Stop: These devices are only for use with air, oxygen and other non hazardous and non combustible gases. The maximum working pressure is 10 bar (145 psi)
For compliance with oxygen systems, please strictly follow the safety guidelines as provided by national laws and/or internal guidelines on use of oxygen equipment.

6.2 Piping table

Check the piping table below and match it for your application. The table shows the amount of upstream and downstream length depending on the installation. If applicable in front of the meter, use given upstream length. If applicable behind the meter, use given downstream length. Gas flow in pipes follows certain rules, which must be observed for optimal measurement results. In some cases the upstream length needs to be longer, in other cases it can be shorter.



If possible, you can always choose a longer upstream length, as these are minimum values. The up- and downstream lengths are used industry wide as guidelines, but will never be a guarantee for obtaining the "true value".

Piping table

The following table provides a guideline for proper distances between upstream or downstream objects and the flow meter. The upstream length is the length between the last non-straight object and the flow meter. If the upstream length is straight, and the distortion is downstream of the flow meter, you can use the column "downstream length" as a guideline. In very complex situations, with multiple up- and downstream objects, you should consider another location. This table is a practical guideline and is not exact science. Practical situations can have multiple sources of distortion, therefore VPIInstruments does not take any responsibility for the correctness.

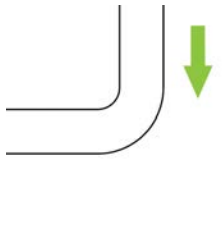
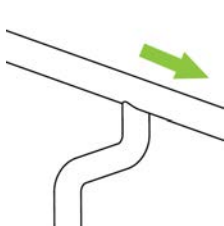
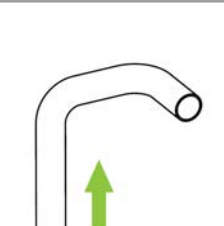
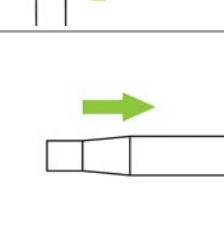
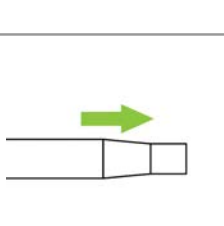
Picture	Description	Upstream length ²	Downstream length ²	Effect
	Single elbow	$30 * D^1$	$10 * D^1$	Distorted flow profile
	Complex feed-in situation (header)	$40 * D^1$	$10 * D^1$	Flow profile will be distorted
	Double elbow, multiple elbows following each other	$40 * D^1$	$10 * D^1$	Distorted profile + swirl
	Diameter change from small to large (gradual or instant)	$40 * D^1$	$5 * D^1$	Jet shaped flow
	Diameter change from large to small (gradual change, between 7 and 15 degrees)	$10 * D^1$	$5 * D^1$	Flattened flow profile

1 = inner diameter; 2 = minimum length

7 Connectivity & communication

The VPFlowScope In-line 3/8" flow meter features two outputs, analog and RS485, which make it possible to connect to VPVision, a central data acquisition / building management system. For the analog output there is an option for 4..20 mA or pulse. Which mode is selected affects how values analog min & max are interpreted.

7.1 LEDES

There are 2 LED's available on the flow meter that indicates the status of the instrument. Various colors and patterns are available.

Color	Patterns	Descriptions
Green	Blinking at 2 seconds interval	Initializing during start up
Green	On	Device is on and started up
Orange	Blinking fast	Modbus communication

7.2 4 .. 20 mA output

The 4..20 mA output can be used to connect to VPVision, a central data acquisition / building management system, a multi-meter or any 4..20 mA based system. The 4..20 mA output is an active current loop.

There is one 4..20 mA output available. This output can be assigned to one of the measurement units. The factory default is l_n/min.

Scaling is done by setting analog min & analog max using a modbus master tool. Analog min & max are the numbers represented by 4 mA and 20 mA. The factory default is analog min on 0, analog max on 50, making 4 mA represent 0 l_n/min and 20 mA represent 50 l_n/min. Scaling is linear.

Refer to the modbus table in [chapter 8 Modbus](#) for register indexes.

Changing analog min & max will not affect the instrument measurement range. Analog out range can be adjusted to narrow or widen the resolution.

4..20 mA output

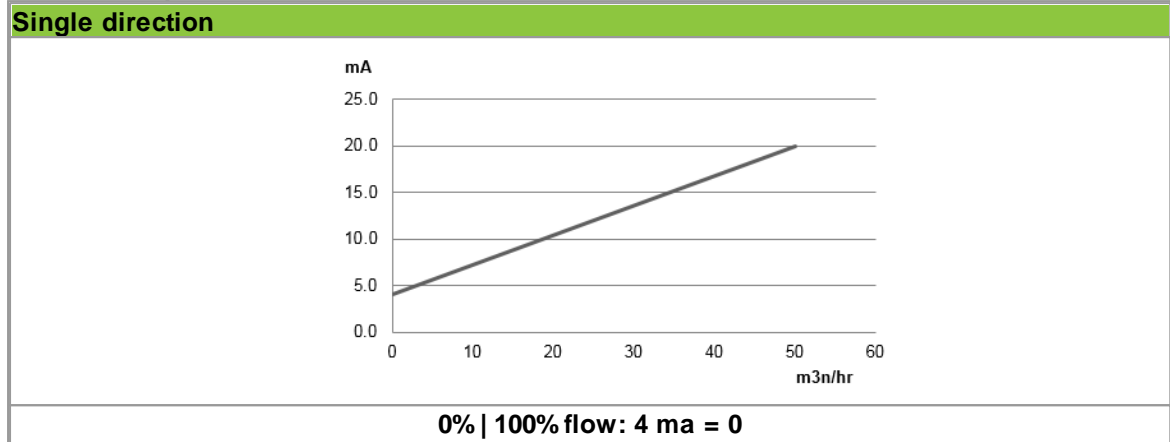

7.3 Pulse

The VPFlowScope In-line 3/8" flow meter features a low-frequency active pulse output. The pulse is a 'non potential' free output as it acts like a controlled current output. To make it passive, an external isolator can be used.

The pulse output is connected to the internal totalizer value. When the totalizer has increased by the pulse interval, the pulse will be generated.

When the analog output is in pulse mode, analog min holds the pulse interval, meaning value represented by a single pulse.

Pulse output

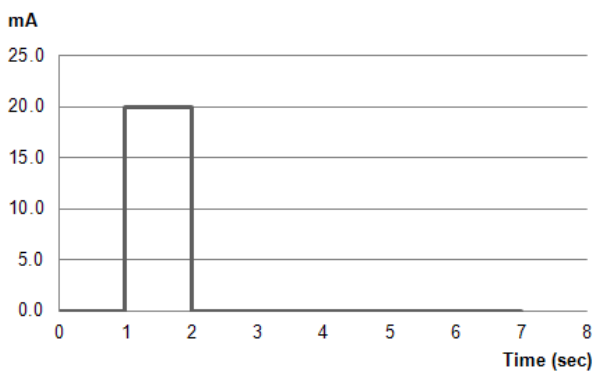

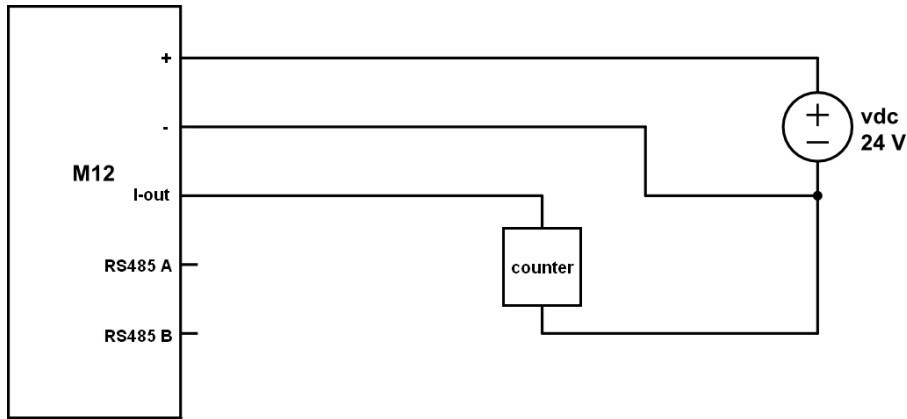
Electrical scheme:

7.4 RS485

RS485 is a serial interface that can be used to connect to VPVision, remote monitoring software or a building management system. The interface is standardized interface according to standard ANSI/TIA/EIA-485-A-98.

It is important to match the communication parameters. All devices using this serial interface need to communicate using the same settings. Various settings are available to match any building management system.

Communication settings

The RS485 communication settings can be changed with the key pads. Below options are available:

- Baud rate: 9600 | 19200 | 38400 | 57600 | 115200
- Stop bits: 1 | 2
- Parity: None | Even | Odd

Factory default is: 38400, 1, none

The communication protocol is **Modbus RTU**. More information can be found in [chapter 8 Modbus](#)

7.5 Display

The display enables you to read measurement data in real time. In combination with the keypad, it can also be used to change the most common parameters.

The display provides 1, 2 or 3 rows for real time data. Each row can be configured in the menu by selecting the desired parameter for this row.

7.5.1 Keypad

The key pad contains 4 buttons to control the flow meter.

**Menu / Enter**

Used to enter the (sub)menu or to confirm a setting

Escape

Will return from a (sub)menu when not in the data acquisition screen

**Button up**

Navigate up in the menu

Button down

Navigate down in the menu

8 Modbus

Introduction to Modbus

A complete introduction on the Modbus standard can be found on www.modbus.org. See the document [Modbus_over_serial_line_V1_02.pdf](#), which can be downloaded from their website. We strongly recommend to download and read this information carefully before installing Modbus communication. The following paragraphs in this chapter assume you are familiar with the Modbus communication standard.

All measurement parameters are available through Modbus in floating point and integer format. The data will be refreshed every second. Maximum polling interval is 10ms.

The Modbus settings can be changed in the menu using the key pad. Below shows all available options

- Hardware address: 1-247
- Integer multiplier: 1-1000

The default settings are hardware address 9 and integer multiplier 10

Data format

Function code 0x03 for reading(Holding register)

Function code 0x06 for writing single register(Holding register)

Function code 0x10 for writing multiple registers(Holding register)

Data format is little-endian word order, big-endian byte order within the word. [CDAB]

Register map

The actual measurement data is placed in holding registers. To read out data, you will need to use the corresponding holding registers.

Counting starts from 0: register 0 is register index 0 (first) and register 1 is register index 1 (second) This table starts with register 1 because register 0 is unused.

HEX	Decimal	Description	Type	Read / Write
<u>General information</u>				
0001 - 0002	1 - 2	Serial number	32-bit integer	Read
0003 - 0005	3 - 5	Firmware version: major, minor, patch	3 words	Read
0006 - 0007	6 - 7	Production date	32-bit integer **	Read
<u>Flow</u>				
0064 - 0065	100 - 101	Flow range min m_n /sec	Floating point	Read
0066 - 0067	102 - 103	Flow range max m_n /sec	Floating point	Read
0068 - 0069	104 - 105	Flow m_n /sec	Floating point	Read
006A - 006B	106 - 107	Flow sfps	Floating point	Read
006C - 006D	108 - 109	Flow m_n^3 /hr	Floating point	Read
006E - 006F	110 - 111	Flow m_n^3 /min	Floating point	Read
0070 - 0071	112 - 113	Flow m_n^3 /sec	Floating point	Read
0072 - 0073	114 - 115	Flow l_n /min	Floating point	Read
0074 - 0075	116 - 117	Flow l_n /sec	Floating point	Read
0076 - 0077	118 - 119	Flow SCFM	Floating point	Read

0082 - 0083	130 - 131	Flow m _n /sec	32-bit integer	Read
0084 - 0085	132 - 133	Flow sfps	32-bit integer	Read
0086 - 0087	134 - 135	Flow m ³ _n /hr	32-bit integer	Read
0088 - 0089	136 - 137	Flow m ³ _n /min	32-bit integer	Read
008A - 008B	138 - 139	Flow m ³ _n /sec	32-bit integer	Read
008C - 008D	140 - 141	Flow l _n /min	32-bit integer	Read
008E - 008F	142 - 143	Flow l _n /sec	32-bit integer	Read
0090 - 0091	144 - 145	Flow SCFM	32-bit integer	Read
<u>Temperature</u>				
00C8 - 00C9	200 - 201	Temp range min	Floating point	Read
00CA - 00CB	202 - 203	Temp range max	Floating point	Read
00CC - 00CD	204 - 205	Temp celsius	Floating point	Read
00CE - 00CF	206 - 207	Temp fahrenheit	Floating point	Read
00D0 - 00D1	208 - 209	Temp Kelvin	Floating point	Read
00E6 - 00E7	230 - 231	Temp celsius	32-bit integer	Read
00E8 - 00E9	232 - 233	Temp fahrenheit	32-bit integer	Read
00EA - 00EB	234 - 235	Temp Kelvin	32-bit integer	Read
<u>Totalizer</u>				
00FA - 00FB	250 - 251	Totalizer m ³ _n	Floating point	Read
00FC - 00FD	252 - 253	Totalizer positive m ³ _n	Floating point	Read
00FE - 00FF	254 - 255	Totalizer negative m ³ _n	Floating point	Read
0100 - 0101	256 - 257	Totalizer MSCF	Floating point	Read
0102 - 0103	258 - 259	Totalizer positive MSCF	Floating point	Read
0104 - 0105	260 - 261	Totalizer negative MSCF	Floating point	Read
0113 - 0114	275 - 276	Totalizer m ³ _n	32-bit integer	Read
0115 - 0116	277 - 278	Totalizer positive m ³ _n	32-bit integer	Read
0117 - 0118	279 - 280	Totalizer negative m ³ _n	32-bit integer	Read
0119 - 011A	281 - 282	Totalizer MSCF	32-bit integer	Read
011B - 011C	283 - 284	Totalizer positive MSCF	32-bit integer	Read
011D - 011E	285 - 286	Totalizer negative MSCF	32-bit integer	Read
<u>Alarm</u>				
0130 - 0131	304 - 305	Alarm counter	32-bit integer	Read
0132 - 0132	306 - 306	Alarm status	16-bit integer, true/false	Read
<u>Alarm/Analog out</u>				
0136 - 0137	310 - 311	Analog low boundary **	Floating point	Read / write
0138 - 0139	312 - 313	Analog high boundary **	Floating point	Read / write

Configuration registers				
03E8 - 03E8	1000 - 1000	Totalizer reset all	16-bit	Write, any value
03E9 - 03E9	1001 - 1001	Alarm counter reset	16-bit	Write, any value
0422 - 0422	1058 - 1058	Analog output unit	16-bit integer	Read / write
0423 - 0423	1059 - 1059	Analog output mode	16-bit integer	Read / write
044C - 044D	1100 - 1101	Diameter mm	Floating point	Read / write
04B0 - 04B0	1200 - 1200	Modbus address	16-bit integer	Read / write
04B1 - 04B1	1201 - 1201	Modbus multiplier	16-bit integer	Read / write

* Unix epoch time stamp

** Value will only change if both registers are written

Available write operations

Option	Data	Description
4..20 mA	2	m ³ n/hr
	3	m ³ n/min
	4	mn/sec
	5	ln/min
	6	ln/sec
	7	SCFM

9 Electrical connections



NEVER USE AC POWER. THIS WILL VOID WARRANTY AND BRING PERMANENT DAMAGE TO THE ELECTRONICS. THE INSTRUMENT MIGHT BE DAMAGED BEYOND REPAIR.
CONNECT THE M8 CONNECTOR BEFORE POWERING UP THE INSTRUMENTS.

The VPFlowScope In-line 3/8" flow meter is equipped with a M8 5-pin connector which contains the power input, an analogue output and a Modbus interface.

Pin	Signal	Wire color
1	+14 .. 24 VDC	Brown
2	0 Volt	White
3	4..20 mA signal, active	Blue
4	RS485 B	Black
5	RS485 A	Grey

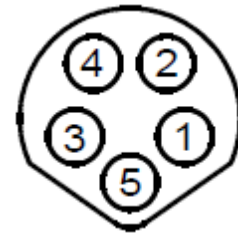

M8 5-pin female connector

* Wire colors apply to VPInstruments cables

Cabling

Shielded twisted pair cabling must be used for proper communication and measurement. Connect shield to safety ground on one point. The thickness of the wires depends on the cable length. For cabling below 300 meter | 1000 ft, use 20 awg. For longer runs use 18 awg or better.

Power supply

The input voltage is 14 .. 24 VDC. Make sure that the power supply is at least 14 VDC at the connector. Voltage drops will occur in long cables resulting in insufficient power. The display will notify you when there is insufficient power.

9.1 4 .. 20 mA

An advantage of a current loop is that the accuracy of the signal is not affected by voltage drop over the line. Even if there is significant electrical resistance in the line, the current loop transmitter will maintain the proper current, up to its maximum voltage capability. The live-zero represented by 4 mA allows the receiving instrument to detect some failures of the loop. An analogue current loop can be converted to a voltage input with an external third party precision resistor.

The transmitter output is an active, non- isolated linearized current loop. This means that the + wire is shared between power supply and the analogue output. A current will draw back from the instrument to the power supply.

Cabling

3 wires are required to create a current loop. It is advised to use a shielded cable to prevent electrical noise to affect the signal.

Ohm's law can be used to calculate the maximum distance. There are 2 parameters that needs to be taken into account.

1. The voltage available is equal to the input voltage
2. The resistance depends on cable quality and length

Example:

Input voltage 24 V
 Required maximum current 20 mA

$24\text{ V} / 0.02\text{ A} = 1200\text{ Ohm}$

1200 Ohm is the maximum load that can be applied with a 24 V input level.

Above example does not include the current consumption of the flow meter itself. When power to the flow meter is applied using a long cable, include a current consumption of 500mA to the formula.

Electrical scheme

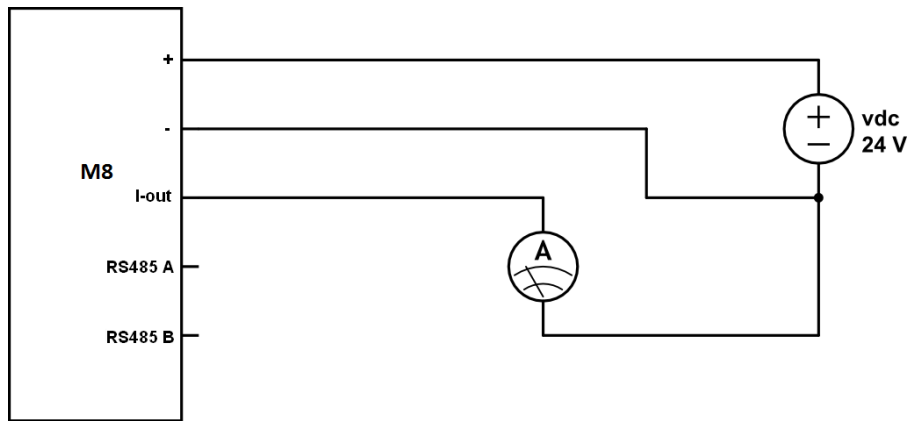

The current meter is placed in between the current output and the power supply ground. You can also use a digital multimeter to test the current output.

9.2 RS485

Installing a RS485 network require specific knowledge. Not following the specifications strictly might result in in-correct communications and equipment damage. Please leave installation up to professional contractors. Make sure that they read this chapter carefully and follow up all RS485 guidelines.

RS485 is a differential balanced line over twisted pair. It can span relatively large distances up to 1200 meter | 4000 feet. The wires should be connected as a point-to-point configuration, or also called daisy chain. Do not install as star or ring network! The trunk line goes from the master to all devices making a drop down to each device. The cable length from the trunk line to the Modbus device needs to be as small as possible. Junction boxes are used to make the T junction.

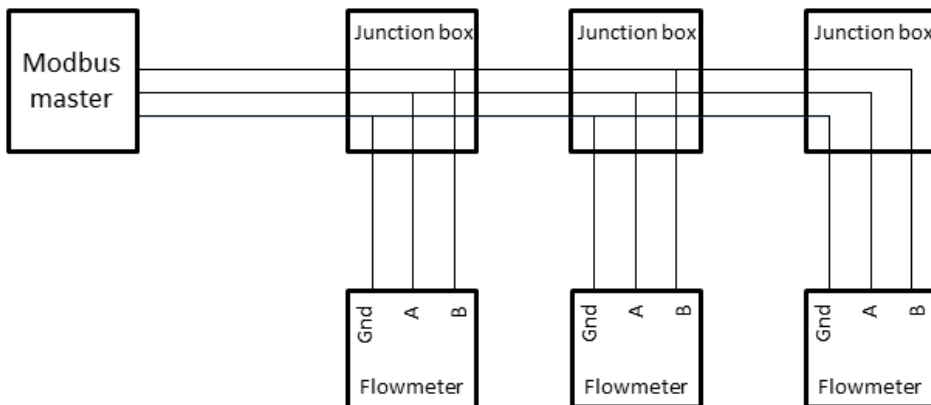

Shielded twisted pair should be used. Connection of a third wire between the master and slave should be done to limit the common mode voltage that can be impressed on the slaves inputs. The required cable quality depends on the total cable distance, the number of nodes and the environmental influences. A local contractor can help you select the right cable for your application.

Termination resistor

Termination resistors reduce electrical noise sensitivity. They need to be added to the installation when cable distances become longer than 10 meter. The value of each termination resistor should be equal to the cable characteristic impedance (typically, 120 ohms for twisted pairs).

There can only be one termination resistor at the very end of the trunk line. The VPInstruments junction box features a jumper that can be used to enable a 120 Ohm resistor. When using the VPInstruments Modbus Junction boxes make sure that the 120 Ohm resistor is only enabled in the last Modbus Junction box in the daisy chain.

Biasing

When there is no data activity on an RS485 network, the communications lines are "floating" and, thus susceptible to external noise or interference. Receivers on a RS485 network have built in hysteresis (200mV differential required to insure known state). To insure that a receiver stays in an inactive state, when no data signal is present, bias resistors are required. Bias resistors are a pull-up resistor on Modbus B and a pull-down resistor on the Modbus A line. The value of the bias resistor depends on the number of devices and the supply voltage. The table below shows which resistor values can be used for different voltage in a chain with 1 to 8 VPFlowScope M's.

Supply voltage	Bias pull up	Bias pull down
12 V	5 K	1 K
24 V	10 K	1 K

Bus power

The flow meter can be powered via the same trunk line. 2 separate wires are used for power + and power -. Take in account that long wires with multiple slaves will cause voltage drops. The minimum supply voltage is 12VDC measured at the last flow meter in the daisy chain.

Electrical scheme

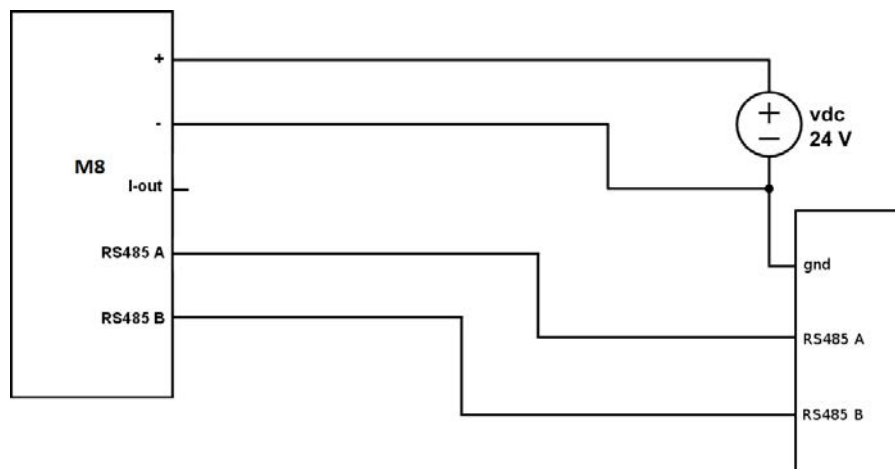

10 Specifications



Please always check the label of your product for the specifications.
Specifications are subject to change as we are continuously improving our products.
Please contact us to obtain the latest specification sheet.

Flow sensor

Measuring principle	Thermabridge™ Thermal Mass Flow sensor
Flow range	2.15 .. 50 l/min 0.09 .. 1.77 CFM
Accuracy	5 % of full scale under calibration conditions
Temperature sensitivity	< 1% of measured value per °C
Reference conditions	20 °C, 1000 mbar 68 °F, 14.50 psi
Gases	Oxygen and compressed air
Gas temperature range	20 .. 32 °C 68 .. 89.6 °F

Display

Display type	1.8" TFT with auto power save
LED status	LED indicators on all models for power and communication

Outputs

RS485	Modbus RTU
Analogue output	4..20 mA output

Mechanical & Environmental

Dimensions	118 x 42 x 61 mm 4.6 x 1.7 x 2.4 inch
Weight	400 grams 14.11 ounces
Material	Brass, polycarbonate
Wetted materials	Brass, Ceramic, Polyurethane, Viton
Protection grade	IP54 NEMA 3
Ambient temperature	0 .. 50 °C 32 .. 122 °F
Ambient humidity	0 .. 95 %. Avoid condensation at all times
Pressure rating	PN10

Avoid direct sunlight or radiant heat
Highly corrosive or acid environments should be avoided

Electrical

Supply	14 VDC(*) .. 24 VDC +10% CLASS 2 (UL)
Power consumption	1 Watt (no flow) 3.5 Watt (full flow) +/- 10%

Certification

CE	EN 60950-1, EN 61326-1, EN 61000-3-2, EN 61000-3-3, EN 61326-1
----	--

easy insight into energy flows

VPInstruments

Buitenwatersloot 335
2614 GS Delft
The Netherlands
info@vpinstruments.com
www.vpinstruments.com

MAN-VP-VP38-EN-2100

Date: 25-01-2021



INSTRUMENTS